

# CableCat

## Wide Base Cable Support Clips (continued from page 162)

### Sizing Chart

CATALOG NUMBER	FIG. NO.	DESCRIPTION	QTY. PER BOX
CAT12*	1	Up to 16 4-pair UTP or 2-strand fiber optic cable – 3/4" dia. loop.	50
CAT21†	1	Up to 50 4-pair UTP or 2-strand fiber optic cable or innderduct 1 5/16" dia. loop.	80
CAT32†	1	Up to 80 4-pair UTP or 2-strand fiber optic cable or innderduct 2" dia. loop.	60
CAT64 	1	Up to 300 4-pair UTP or 2-strand fiber optic cable 4" dia. loop.	25
CATHBA	2	Angled hanger bracket.	40
S3575BP100	3	1/4" - 3/8" round head screw.	100
S3575DP100	3	1/2" - 3/4" round head screw.	100
CATTRC	4	Plenum rated tie wrap (optional).	100
CATTS*	5	Support from tee grid.	20

#### Kits For Category 5 Cable Hangers

CAT KITA	6	CAT32 – 20 pieces / CATHBA Hanger–5 pieces BC200 Beam Clamps – 5 pieces.	1 Kit
CAT KITB	6	CAT21 – 10 pieces / CAT32 – 10 pieces CATHBA Hanger – 5 pieces BC200 Beam Clamps – 5 pieces (screws included).	1 Kit
CAT KITC	6	CAT21 – 20 pieces / CATHBA Hanger–5 pieces BC200 Beam Clamps – 5 pieces (screws included).	1 Kit

† Available in stainless steel  
\*CAT12 and CAT12 assemblies include bend back tab.

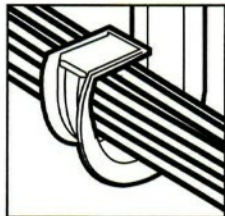

(continued on page 164)

 New 4" hook available for Fall '99.  
Contact factory for combos.

Read safety instructions and instruction sheets contained in packages before using or applying fastener.

**LOW VOLTAGE**  
**Datacomm**

**CADDY**

163

# CableCat™

PATENT PENDING

## Wide Base Cable Support

### Features

- Provides proper support of Category 5, fiber optic and innerduct.
- Variety of sizes and designs available to attach to virtually any structure.
- Cost effective alternative to expensive cable tray.
- Galvanized finish on J-hooks provide smoother cable pull and greater corrosion resistance.
- Complies with UL, cUL, NEC and EIA/TIA requirements for structured cabling systems.

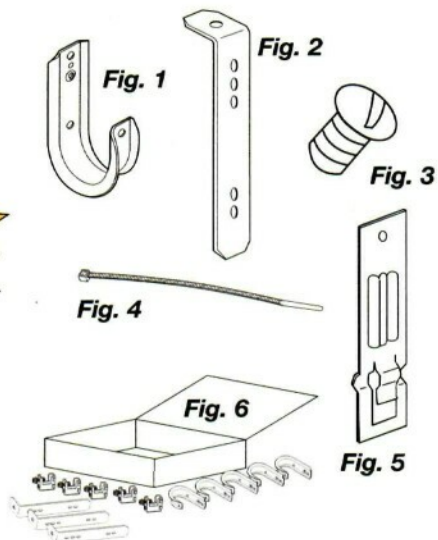

### Applications

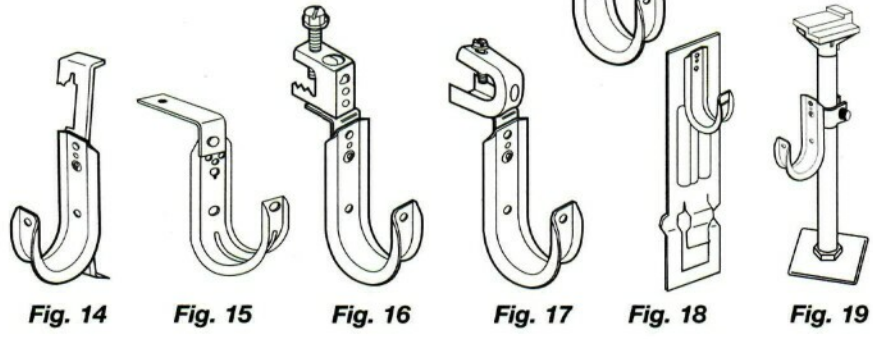
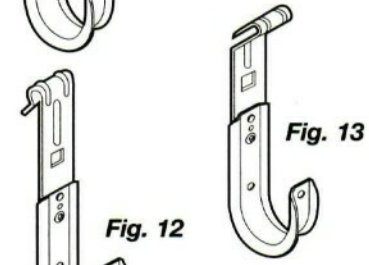
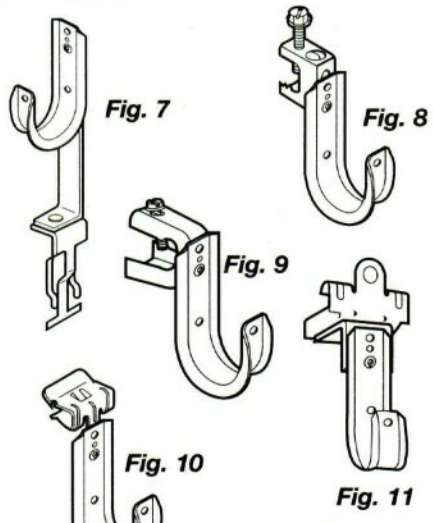
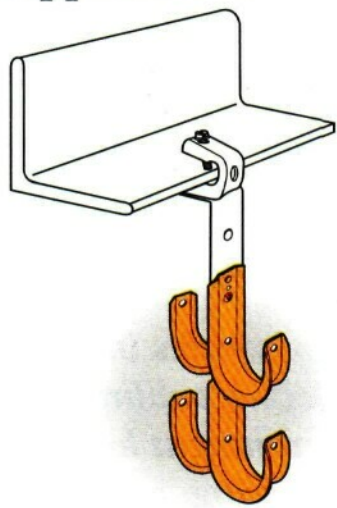

## LOW VOLTAGE Datacomm

Read safety instructions and instruction sheets contained in packages before using or applying fastener.

