

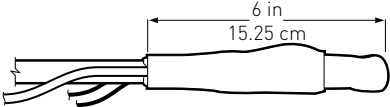

CONNECTION KITS AND ACCESSORIES

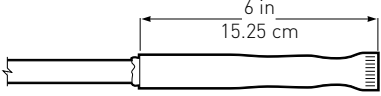
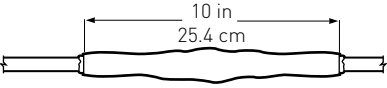

CONNECTION KITS

Catalog number	Part number	Description
EMK-XP	579519	The power connection and end seal kit is a water-resistant electrical assembly that is sealed with a proprietary adhesive and protected by a crosslinked, modified polyolefin heat-shrinkable tube.
 <p>Power connection EMK-XP</p>		<p>Storage temperature: -40°F to 140°F (-40°C to 60°C) Minimum installation temperature: 0°F (-18°C) Power connection wire range: 14 to 4 AWG Voltage rating: 600 V Packaging: One power connection and one end seal per box Shipping weight: 0.4 lb (182 g)</p>
 <p>End seal EMK-XP</p>		
EMK-XS	356667	The splice kit is a water-resistant electrical assembly that is sealed with a proprietary adhesive and protected by a crosslinked, modified polyolefin heat-shrinkable tube.
		<p>Storage temperature: -40°F to 140°F (-40°C to 60°C) Minimum installation temperature: 0°F (-18°C) Voltage rating: 600 V Packaging: One splice kit per box Shipping weight: 0.2 lb (91 g)</p>

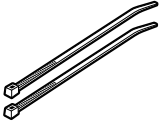
ACCESSORIES

Catalog number	Part number	Description
EMK-XJR	693647	The jacket repair kit is a heat-shrinkable wrap-around sleeve for covering a damaged outer jacket. The repair sleeve is adhesive-lined and comes with a removable metal closure.
 <p>Metal closure</p> <p>ShrinkWrap™ sleeve</p>		<p>Nominal length: 12 in (30.5 cm) Packaging: One repair sleeve per kit Shipping weight: 0.8 lb (365 g)</p>
EMK-XCT	906441	The nylon cable ties are seven-inch nylon industrial cable ties.
		<p>Manufacturer: Panduit Model number: PLT2S-C Length: 7-3/8" ± 1/2" (18.74 cm ± 1.25 cm) Width: 3/16" (0.48 cm) Packaging: 100 per pack Shipping weight: 0.5 lb (227 g)</p>

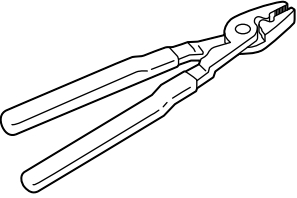
ACCESSORIES

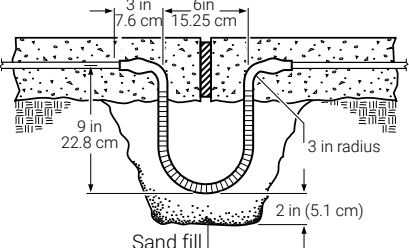
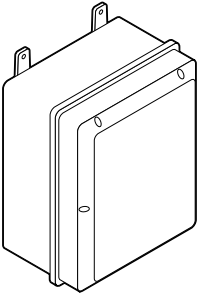
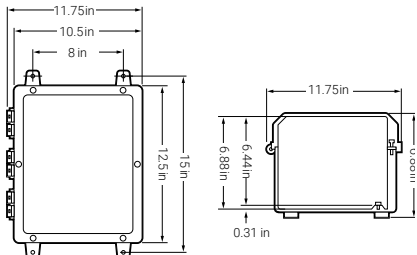
Catalog number	Part number	Description
EMK-XT 	980631	<p>The crimping tool is the correct size for the crimps in the connection kit.</p> <p>Manufacturer: Ideal Model number: 30-425 Length: 10" (25.4 cm) Packaging: One per kit Shipping weight: 1.2 lbs (545 g)</p>
SMCS 		<p>Snow melt caution sign Dimensions 6 x 4 in (150 x 100 mm)</p>
EMK-XEJ 	472207	<p>The expansion joint kit provides physical protection for the heating cable beneath slab joints. An expansion tube is used to form an expansion loop for the heating cable.</p> <p>Storage temperature: -40°F to 140°F (-40°C to 60°C) Minimum installation temperature: 0°F (-18°C) Packaging: One expansion joint per kit Shipping weight: 0.3 lb (140 g)</p>
EMK-XJB  	052577	<p>The junction box is a large, UL Listed weatherproof enclosure suitable for terminating both ends of an ElectroMelt heating cable circuit. This junction box is large enough for 2 circuits of ElectroMelt heating cables. The enclosure is made of molded structural foam and provides high impact strength, excellent chemical resistance, high dielectric strength, and excellent weathering capabilities.</p> <p>Manufacturer: Carlon, model CJ12106 Inside dimensions: 12" x 10" x 6-7/8" (30.5 cm x 25.4 cm x 17.5 cm) Inside volume: 825 cubic inches (13528 cm³) Outside dimensions: 15-1/2" x 11-3/4" x 7-5/8" (39.4 cm x 29.85 cm x 19.37 cm) Temperature range: -40°F to 185°F (-40°C to 85°C) UL Standard: UL508 NEMA rating: Types 1, 3, 3S, 3X, 3SX, 4, 4X, 12, 13 as indicated Packaging: One junction box per kit Shipping weight: 5.4 lbs (2.45 kg)</p>

APPROVALS



877Z De-icing and
Snow-melting
Equipment



The EM2-XR heating cable is UL Listed and CSA Certified only when used with the appropriate agency-approved Thermal Management connection kits and accessories.

DESIGN AND INSTALLATION

For proper design and installation of an Electromelt connection kit, use the appropriate product design guide and the installation instructions included with the connection kit.

GROUND-FAULT PROTECTION

To minimize the danger of fire from sustained electrical arcing if the heating cable is damaged or improperly installed, and to comply with the requirements of nVent, agency certifications, and national electrical codes, ground-fault equipment protection must be used on each heating cable branch circuit. Arcing may not be stopped by conventional circuit protection. Many Raychem control and monitoring systems meet the ground-fault protection requirement.

North America

Tel +1.800.545.6258

Fax +1.800.527.5703

info@nvent.com



nVent.com

Our powerful portfolio of brands:

CADDY ERICO HOFFMAN RAYCHEM SCHROFF TRACER