

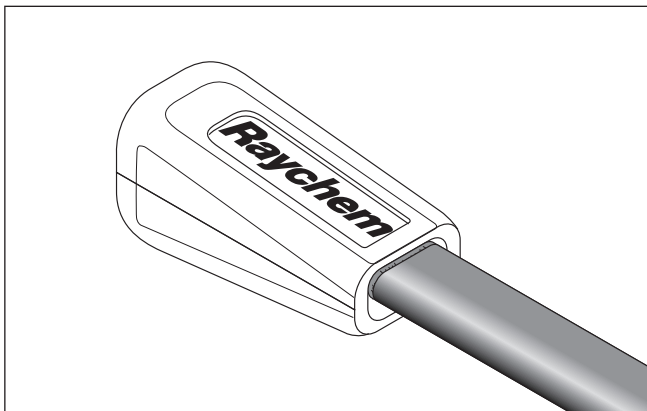

RAYCHEM

H912

Gel-filled End Seal Kit Installation Instructions



DESCRIPTION

The nVent RAYCHEM H912 is a replacement end seal kit for terminating the following nVent RAYCHEM heating cables: H311, H611, H612, H621, and H622 only. The kit contains materials for two end seal terminations. This kit does not provide a power connection; an H900 or H908 Power Connection Kit (supplied separately) must be used to comply with warranty, approvals, and national electrical code requirements. For technical support call nVent at (800) 545-6258.

TOOLS REQUIRED

- Utility knife
- Diagonal cutters

APPROVALS



718K Pipe Heating Cable
877Z De-icing and Snow Melting Equipment



-W

KIT CONTENTS

Item	Qty	Description
A	2	Gel-filled end seal
B	2	Black cloth tapes (6 in. long)—for use with H311, H611, and H621.

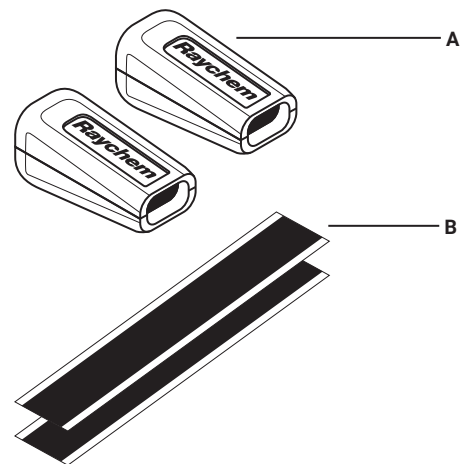

WARNING:

The end seal must be installed properly to ensure proper operation and to prevent shock or fire. Read these important warnings and carefully follow all of the installation instructions.

- To minimize the danger of fire from sustained electrical arcing if the heating cable is damaged or improperly installed, and to comply with the requirements of nVent, agency certifications, and

national electrical codes, ground-fault equipment protection must be used. Arcing may not be stopped by conventional circuit breakers.

- Bus wires will short if they contact each other. Keep bus wires separated.
- The black heating cable core is conductive and can short. It must be properly insulated and kept dry.

- Keep components and cable ends dry before and during installation.
- Component approvals and performance are based on the use of nVent-specified parts only. Do not use substitute parts or vinyl electrical tape.
- Use only fire-resistant insulation materials such as fiberglass wrap.

Note: The end seal is designed to be installed only once; it cannot be removed from the heating cable once installed.
Do not use until ready for final installation.

1 End Seal for H612, H622

- Cleanly cut off the end of the cable.
- Score down and around outer jacket 1 inch from the end.
- Remove the outer jacket.
- Do not cut or damage inner jacket.

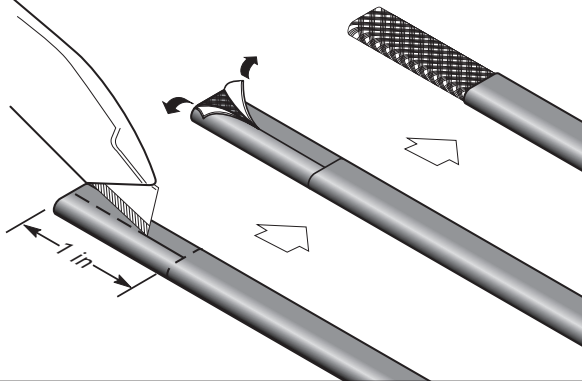

2 End Seal for H612, H622

- Unravel and remove exposed braid.

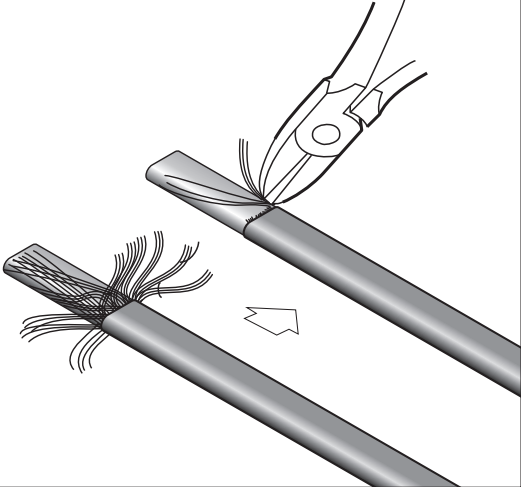

3 End Seal for H612, H622

- Firmly push end seal onto the cable (at least 1 1/2 inch). Some gel may ooze out.
- Do not twist or try to remove the end seal during or after insertion. Do not reuse an end seal.

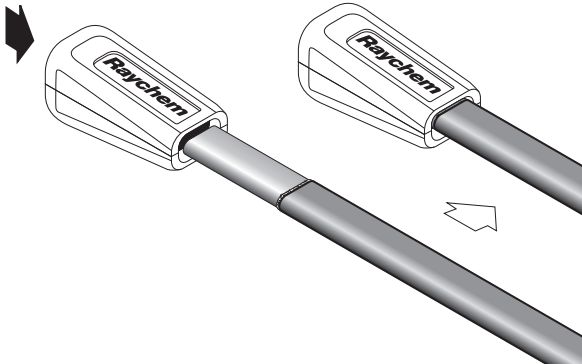

Note: The end seal is designed to be installed only once; it cannot be removed from the heating cable once installed.
Do not use until ready for final installation.

1 End Seal for H311, H611, H621

- Cleanly cut off the end of the cable.

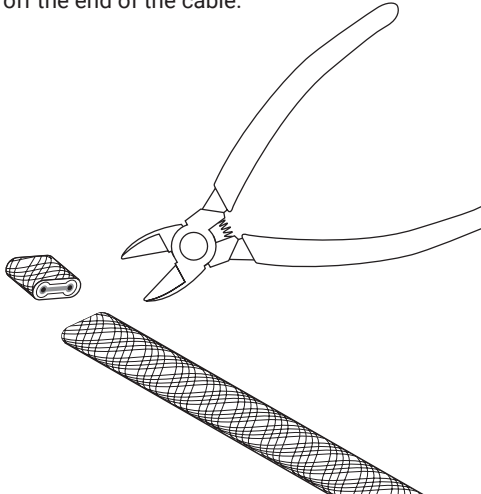

2 End Seal for H311, H611, H621

- Push the braid back 2 inches from the cable end.

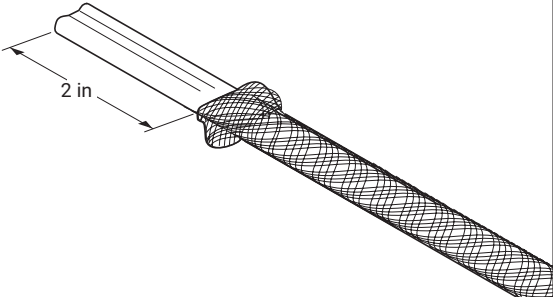

3 End Seal for H311, H611, H621

- Firmly push end seal onto the cable (at least 1 1/2 inch). Some gel may ooze out.
- Do not twist or try to remove the end seal during or after insertion. Do not reuse an end seal.

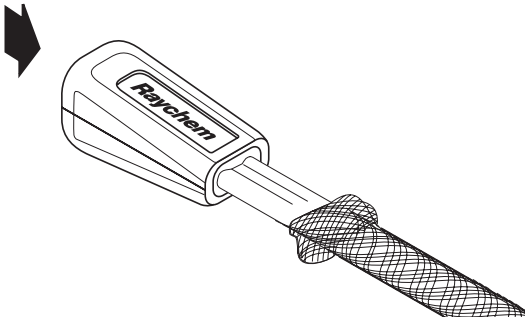

4 End Seal for H311, H611, H621

- Slide the braid up against the end seal and secure with the 6-inch length of tape provided.

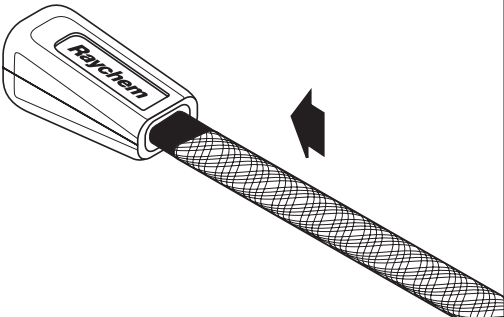

NORTH AMERICA

Tel +1.800.545.6258
Fax +1.800.527.5703
thermal.info@nvent.com

EUROPE, MIDDLE EAST, AFRICA

Tel +32.16.213.511
Fax +32.16.213.604
thermal.info@nvent.com

ASIA PACIFIC

Tel +86.21.2412.1688
Fax +86.21.5426.3167
cn.thermal.info@nvent.com

LATIN AMERICA

Tel +1.713.868.4800
Fax +1.713.868.2333
thermal.info@nvent.com



nVent.com