

Models

Sensors:

HBP-111-L7, with IR remote capability
HBP-112-L7, no IR capability

Mounting Modules:

HBP-EM1 extender module
HBP-SM1 surface mount module

Wireless Remote Configuration Tool:

FSIR-100

Specifications and Features

Indoor use only

Operating Temperature: 32°F to 158°F
(0°C to 70°C)

Operating Humidity: 5% to 95%, non-
condensing

Line voltage for direct connection to
load

120, 277, 347V, 60Hz or 230V, single
phase, 50Hz operation

Power consumption: 0.2W

Adjustable time delay and sensitivity

Adjustable hold-off daylighting level

Snap-in mounting hardware

Weight: 6.4 oz (181 g)

Easy mounting using knockout at end
of fluorescent high bay luminaire

Flexible mounting options

UL and cUL listed

Five year warranty

Optical

Lens (attached) designed for mount-
ing heights from 15 to 40 feet

Snap-on rotatable mask for aisleway
applications (included)

Covers a 100-foot diameter area when
mounted at a height of 40 feet

Materials

ABS, flame retardant
Impact resistant
Recyclable
RoHS compliant

Factory Defaults

Time Delay: 15 minutes
Sensitivity: Max
Light Level: 300 footcandles

High/Low Bay Passive Infrared Occupancy Sensor



Product Overview

The HBP-100 series occupancy sensors are designed for automatic lighting control in high or low bay applications. All models contain a passive infrared (PIR) sensor and a lens engineered to provide reliable coverage from a wide range of mounting heights.

Sensitivity and time delay adjustments are set using trimpots conveniently located on the sensor module. The HBP-111 can also be adjusted remotely using a handheld configuration tool (FSIR-100).

Both models include a hold-off daylighting light level feature to prevent lighting from turning on when occupancy is detected when there is sufficient ambient light available.

The HBP-111 includes extra features that can be enabled or disabled via the FSIR-100. Features include burn-in mode, walk-through mode, visual alert and occupancy mode

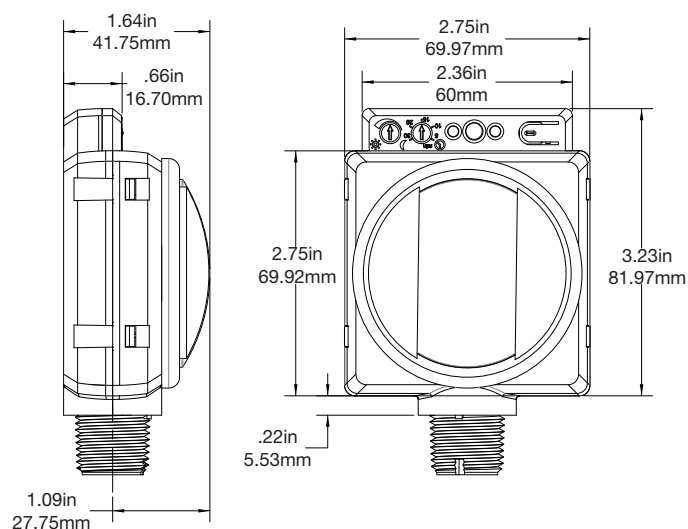

HBP-11x Sensor Dimensions

Lens, Masking and Coverage

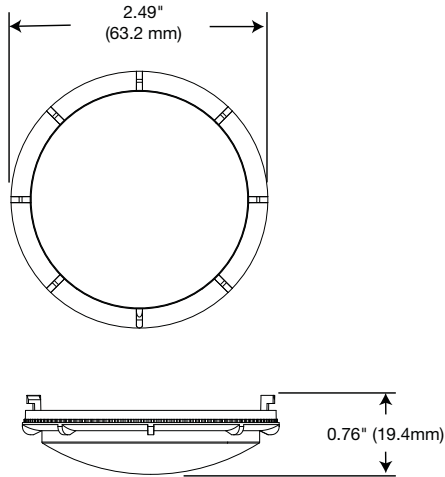

HBP-L7 Lens Dimensions

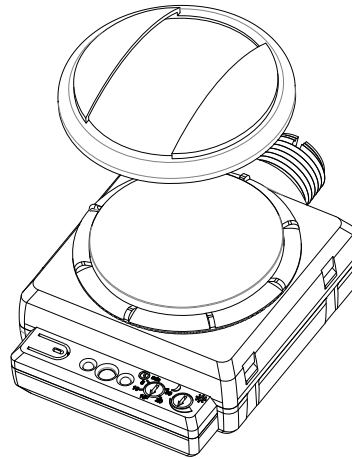

HBP-111 shown with snap-on rotatable mask for aisleway coverage (included with sensor)

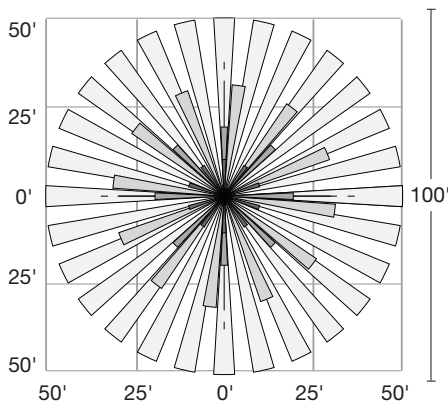

HBP-L7 top coverage pattern

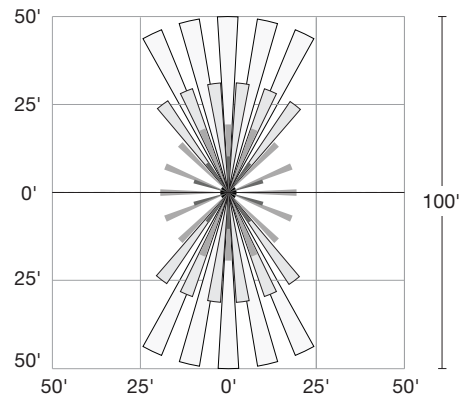

HBP-L7 top coverage pattern with mask

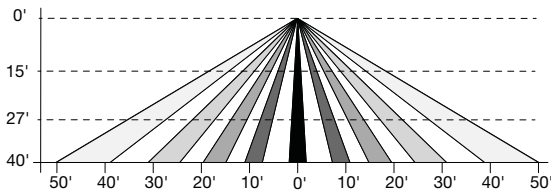

HBP-L7 side coverage pattern

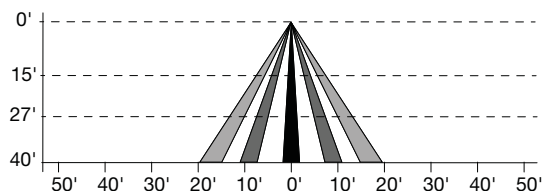

HBP-L7 side coverage pattern with mask

Passive Infrared Sensing in Warehouses

Warehouses can have ambient temperature variations that may affect sensor detection and coverage areas. High temperatures at the covered area (above 80°F) reduce the detection zone of the sensor. Consider adding more sensors if the ambient temperatures are expected to be high. Ad-

ditionally, high floor level temperature may require larger movement for detection. In some cases, sensors mounted above 40' may only detect large heat signatures such as forklift trucks. See the Best Practices Guide for Warehouse at www.wattstopper.com for more information.

Installation and Mounting Instructions

1. Determine the mounting location appropriate to the features of the sensor and the coverage area.
2. Avoid placing the sensor where the edge of the fixture, shelving or other obstructions may block the sensor's line of sight. Mount the sensor below the edge of the fixture and away from the fluorescent lamps so that the heat from the lamps does not affect the sensor.
3. If using the hold-off daylighting light level feature, avoid mounting in location where adjacent fixtures contribute to the photocell measurement.
4. Make sure that you have the appropriate accessories for the sensor mounting configuration. The EM1 Extender Module positions the sensor below the fixture

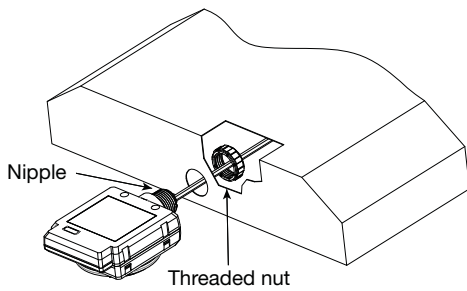

Figure 1. Direct Mounting to Fixture

Note: To prevent false triggering, the sensor must be mounted at least 1/2" away from the lamp and the sensor lens must be below the fixture.

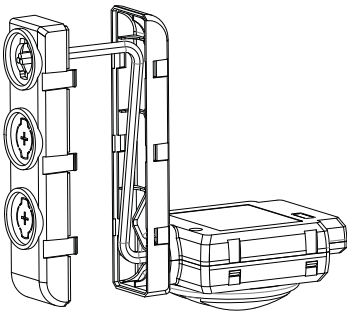

Figure 3. EM1 Extender Module Assembly

[see Figures 2 and 3]. The SM1 Surface Mount Module includes clips to hold the sensor to the bottom of the fixture (see Figure 4).

5. Assemble any necessary mounting accessories and attach them to the sensor, making sure that the flying leads from the power module are accessible.
6. Connect the line voltage and load wires to the sensor leads as shown in the Wiring Diagram (see page 6).
 - Do not allow bare wire to show.
 - Make sure all connections are secure.
7. Restore power from the circuit breaker.

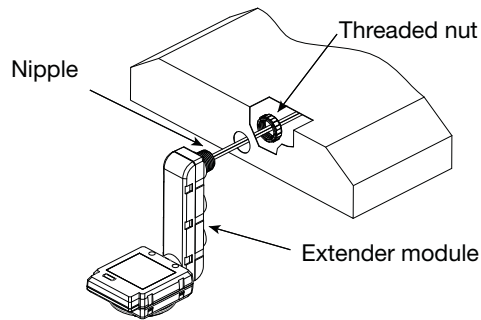

Figure 2. EM1 Mounting Below Fixture

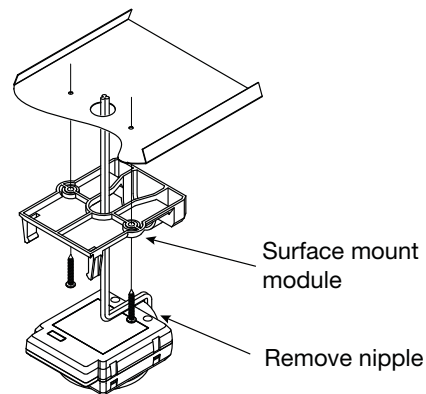

Figure 4. SM1 Mounting to Bottom of Fixture

Important Start-up Information

A 60-second start-up period occurs during initial installation and after a power failure of 5 minutes or more. After applying power to the sensor, wait at least 60 seconds for the sensor to begin detecting occupancy and the load to turn ON. Regardless of light level the load may turn ON during the start-up period, depending on the state of the relay when power was off.

- If the sensor detects occupancy during the start-up,

when the load turns ON it stays ON as long as the sensor continues to detect motion, plus the Time Delay.

- If no occupancy is detected during the 60-second start-up, the load may come on anyway during the start-up. If no occupancy is detected by the time the start-up is complete, the relay opens and the load turns OFF.

Adjustable Control Parameters

Setting Time Delay

Trimpot

1. Adjust the trimpot to the desired time delay (hard stop settings: 5, 10, 15, 20, 30 minutes; default 15 minutes).

FSIR-100 Remote (HBP-111 only)

1. Aim the remote at the IR receiver on the sensor
2. Select "Adjust Time Delay"
3. Choose from the range of 1 min - 30 mins with 1 minute increments
4. Select "Send"; remote displays "Settings Received"

Setting Motion Detection Sensitivity (factory default setting is ideal for most applications)

Trimpot

1. Hold push button for approx. 3 seconds to enter test mode
2. Adjust the Time Delay trimpot to the hard stop setting for the desired sensitivity (options: 5 or 10 min = Low; 15 or 20 min = Med; 30 min = Max; default Max)
3. Hold push button for approx. 3 seconds to exit test mode
4. Return Time Delay to desired setting

FSIR-100 Remote (HBP-111 only)

1. Aim the remote at the IR receiver on the sensor
2. Select "New Settings" and "Sensitivity"

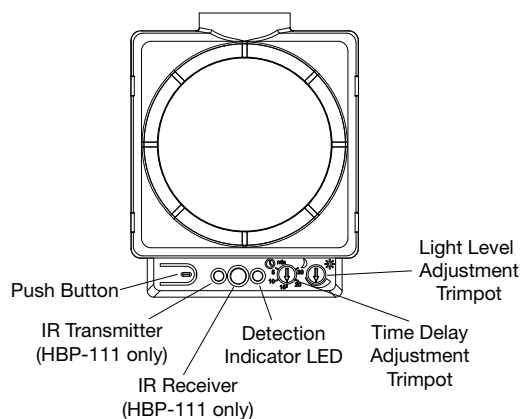

Figure 5. Sensor Controls

3. Choose from the options of Low, Med or Max
4. Select "Send"; remote displays "Settings Received"

Setting Light level Hold-Off

Adjust during daylight hours when ambient light is at the desired level.

Trimpot

1. Adjust the trimpot on the sensor housing to desired photocell setting (analog wheel with hashmarks: 1-300fc; default 300fc).

FSIR-100 Remote (HBP-111 only)

1. Aim the remote at the IR receiver on the sensor
2. Select "Adjust Photocell Setting"
3. Choose from the range of 1fc - 300fc with 1 footcandle increments
4. Select "Send"; remote displays "Settings Received"

The light level values referenced are approximate and reference 4000K CCT. Variations in color temperature may affect the actual levels the sensor sees. It is recommended that light level hold off be set up in the morning for best results.

NOTES: Any adjustments made will override any previous settings whether manually made on the sensor or through the FSIR-100 commission tool.

Adjusting Time Delay does not affect Sensitivity and vice versa.

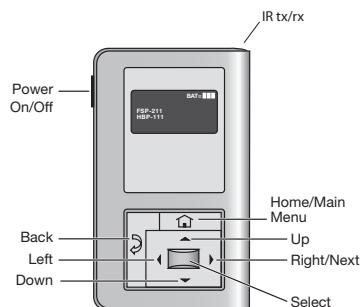

Figure 6. FSIR-100 Remote Configuration Tool

Adjustable Control Parameters, continued

Push Button Functions

The following functions are available via the Push Button.

Manual Mode: To toggle the unit in or out of Manual Mode, quickly press the Push Button to toggle the load ON or OFF. When the load is turned ON manually, it will remain ON as long as motion is detected and the time delay has not expired. If the load is turned OFF manually, the sensor holds the load OFF for as long as motion is detected and then for an additional 5 minutes of no motion detection. The next time the sensor detects occupancy, and the ambient light is lower than the established light level, the sensor automatically turns ON the load.

Test Mode: To place the unit in a 10 minute Test Mode, press the Push Button for about 3 seconds, or enable the Test Mode with the FSIR-100 (HBP-111 only). The LED will flash once confirming you are in Test Mode. To exit Test Mode, press and hold the Push Button for 3 seconds. Walk-test the unit to ensure proper detection.

Service Mode: To toggle the unit in or out of Service Mode, press and hold the Push Button for about 6 seconds. The LED will flash twice confirming you are in or out of Service Mode. In Service Mode, the LED and load will always be ON.

Fail On Mode: Press and hold the Push Button for about 9 seconds to enable Fail ON Mode. The LED will flash three times confirming Fail ON is enabled. In this mode, the sensor will turn the connected loads ON upon restoration

of power. In the event of a sensing failure, this mode will ensure power is still available for connected loads.

Fail Off Mode: Press and hold the Push Button for about 12 seconds to enable Fail OFF Mode. The LED will flash four times confirming Fail OFF is enabled. In this mode, the sensor will keep the connected loads OFF upon restoration of power. The sensor is set to this mode by default.

Factory Default: To manually return the unit to factory default settings, press and hold the Push Button for about 15 seconds. This will return all settings to factory default with the exception of time delay and light level, which will be set to the current trimpot settings.

When using the FSIR-100 remote to return to factory default (HBP-111 only), all settings will be returned to the original factory settings regardless of current trimpot positions.

The LED will remain solid ON confirming it has been reset to the factory default.

Cancel: To prevent any changes from being made, hold the push button for about 18 seconds. For example, if resetting to factory default (or any other setting) is not desired then keep holding until you reach 18 or more seconds. The LED will turn off after 18 seconds to indicate there were no changes made.

Additional Features Available on HBP-111

Use the FSIR-100 handheld configuration tool to disable or enable following modes:

Burn-In Mode: When Burn-In Mode is invoked the output will turn ON for 100 hours continuously. However, the Push Button or remote can be used to turn the load OFF, and the sensor will exit Burn-In Mode. Default setting is Disabled.

Walk-Through Mode: In this mode, the load will turn off after a 3 minute period following an initial occupancy event if there is no motion detected after the first 30 seconds. If occupancy continues beyond the first 30 seconds, the established time delay applies. Default setting is Disabled.

Visual Alert: When enabled, Visual Alert turns the load OFF for 1 second to warn any occupants of impending shutoff 1 minute before the time delay countdown expires. Default setting is Disabled.

Occupancy Mode: When Occupancy Mode is disabled, the LED will always be on; both motion detection and light level functionality are disabled, and only the Push Button or

remote can toggle the load ON and OFF. The default setting for Occupancy Mode is Enabled.

For more information on these modes, refer to the FSIR-100 User Guide by scanning the following QR code or visiting the link, below.



<http://www.wattstopper.com/products/fixture-sensors-and-controls/fixture-sensors/fsp-211.aspx>

Wiring Diagram

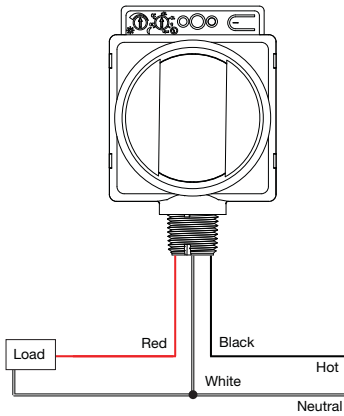

Figure 7. Wiring for HBP-11x

Sequence of Operation

The HBP-100 series occupancy sensor is designed to mount to a light fixture and control the load in the fixture. It can be wired to control all ballasts in the fixture, or to control half of the ballasts to provide high/low lighting control. When motion is detected within the sensor's coverage area, the relay in the sensor closes, and lighting loads turn on automatically. When motion is no longer detected for the duration of the time delay setting, the relay opens and the lighting load is turned off. The sensor's sensitivity and time delay settings are factory preset at 100% and 15 minutes, respectively, which are suitable for most high bay applications. The Light Level feature holds lights off upon initial occupancy if adequate ambient light exists. It will not turn the lights off if they are on. If the ambient light level is lower than the factory preset light level or manually adjusted setpoint, the loads will trigger on once occupancy is detected. The default setting is for maximum, meaning that even the brightest ambient light will not hold the lights off. Refer to the Installation Instructions for additional information, and for important start up instructions.

Ordering Information

Catalog #	Master Pack Details					Inner Pack Details				
	Master Pack Quantity	Case dimensions (inches)			Weight (pounds)	Inner Pack Quantity	Case dimensions (inches)			Weight (pounds)
		Length	Width	Height			Length	Width	Height	
HBP-111-L7-OEM	100	19.88	16.73	21.93	44.09	50	19.44	16.30	10.39	21.38
HBP-111-L7-EM1-OEM	20	19.88	14.72	14.64	13.23	10	19.44	14.29	6.81	6.17
HBP-111-L7-SM1-OEM	100	19.88	14.72	14.64		50	19.44	14.29	6.81	
HBP-112-L7-OEM	100	19.88	16.73	21.93	42.99	50	19.44	16.30	10.39	20.94
HBP-112-L7-EM1-OEM	20	19.88	14.72	14.64	13.23	10	19.44	14.29	6.81	6.17
HBP-112-L7-SM1-OEM	100	19.88	14.72	14.64		50	19.44	14.29	6.81	
HBP-EM1	100	21.38	17.91	16.34	16.53	50	20.63	17.09	7.56	8.38
HBP-L7	100	21.38	17.63	15.86		50	20.63	8.34	15.27	
HBP-SM1	100	21.38	17.91	16.34		50	20.63	17.09	7.56	

Catalog #	Color	Description	Voltage	Load Capacity
<input type="checkbox"/> HBP-111-L7-OEM	White	HBP-111-L7 (Bulk Packaged)	120/230 (1P,L-N) 277/347 VAC	@ 120 VAC, 60Hz: 0-1000 VA, 1/4 hp @ 230 VAC, 50/60Hz: 0-1000 VA @ 277 VAC, 60Hz: 0-1200 VA, 1/4 hp @ 347 VAC, 60Hz: 0-1500VA, 1/4 hp Compatible with tungsten, electronic and magnetic ballasts, fluorescent and LED
<input type="checkbox"/> HBP-111-L7-EM1-OEM	White	HBP-111-L7 and HBP-EM1 (Bulk Packaged)		
<input type="checkbox"/> HBP-111-L7-SM1-OEM	White	HBP-111-L7 and HBP-SM1 (Bulk Packaged)		
<input type="checkbox"/> HBP-112-L7-OEM	White	HBP-112-L7 (Bulk Packaged)		
<input type="checkbox"/> HBP-112-L7-EM1-OEM	White	HBP-112-L7 and HBP-EM1 (Bulk Packaged)		
<input type="checkbox"/> HBP-112-L7-SM1-OEM	White	HBP-112-L7 and HBP-SM1 (Bulk Packaged)		
<input type="checkbox"/> FSIR-100	Black	Remote handheld configuration tool		{3} 1.5V AAA alkaline batteries

Bulk packaged products are shipped without individual boxes or installation instructions. Information supplied above is subject to change. Harmonization Code: 8538907080. Country of origin: China.